

## Installation instructions

**i** Refer to installation use and maintenance manual for more information.  
Available user manual at link <http://www.everelettronica.it/manhw.html>



## BLDC motor drive technical data

- DC power supply:  $12 \pm 48$  Vdc
- DC logic supply:  $12 \pm 48$  Vdc (optional and not isolated)
- Phase current: up to 10Arms (28Apeak for 5s)
- Motor power: up to 400W
- Chopper frequency: ultrasonic 40KHz
- Protections against: over current, over/under voltage, overheating, short circuit between motor phase-to-phase and phase-to-ground
- EtherCAT communication interfaces
- Encoder input (not isolated): 5V Differential (RS422) or 5V Single-Ended (TTL/CMOS) incremental encoder
- Hall input (not isolated): 5V Single-Ended (TTL/CMOS) hall effects
- Service SCI interface for programming and real time debugging
- 4 digital inputs (opto-coupled)
- 3 digital outputs (opto-coupled)
- Dimensions: 139 x 84,5 x 28 mm (without connectors)
- Protection degree: IP20
- Pollution degree: 2
- Category C3 following standard EN 61800-3
- Working temperature  $5^{\circ}\text{C} \pm 40^{\circ}\text{C}$ ; Storage temperature  $-25^{\circ}\text{C} \pm 55^{\circ}\text{C}$
- Humidity:  $5\% \pm 85\%$  not condensing

**Platino**  
BLDC - SERVO - DRIVES

**EtherCAT**

## Mechanical data

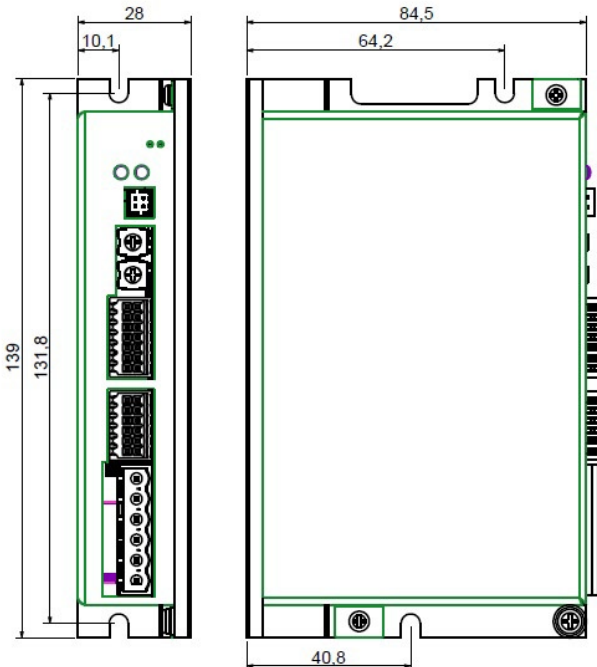

# System connections

Connectors:

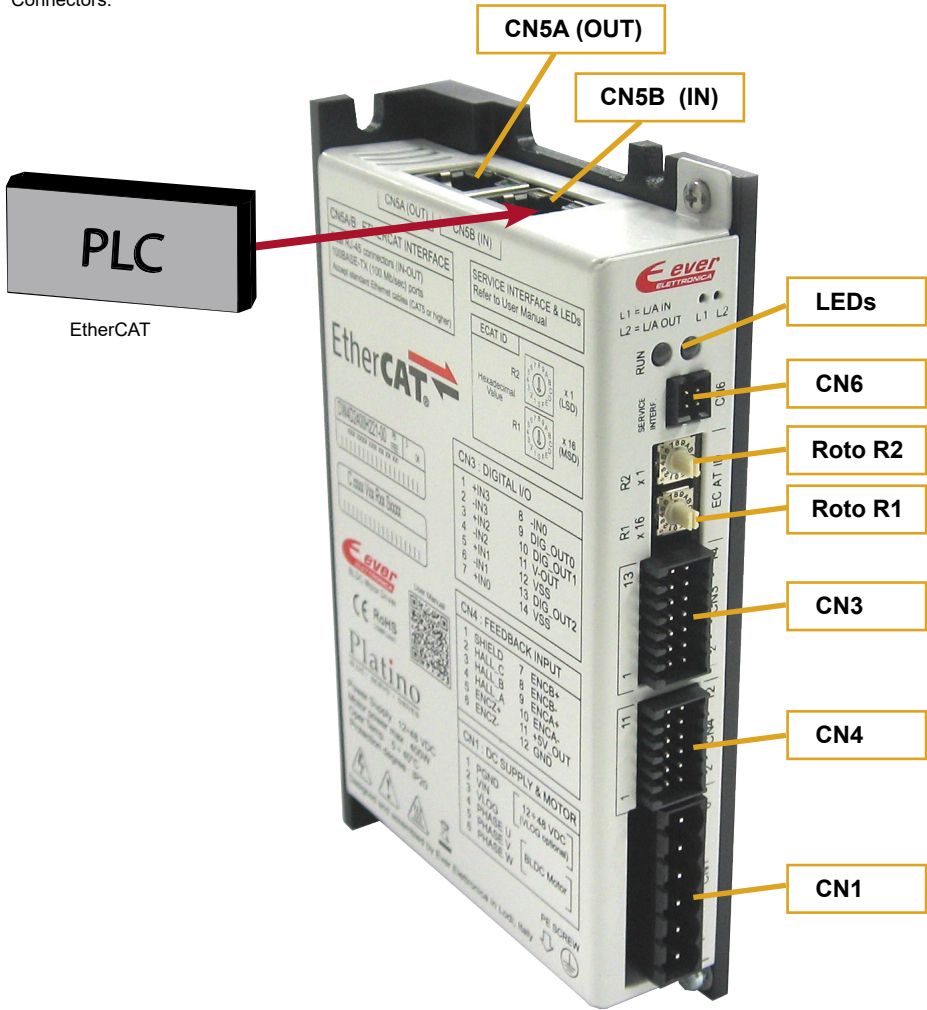

***Power and Logic supplies are not isolated but they have common reference inside the drive.***

# System connection

## CN1: DC Power supply and Motor

6 positions, pitch 5.08mm, PCB header connector

CN1.1	PGND	PWR_IN	Negative DC power supply input
CN1.2	VIN	PWR_IN	Positive DC power supply input
CN1.3	VLOG	PWR_IN	Positive DC logic supply input
CN1.4	U	PWR_OUT	Motor output phase U
CN1.5	V	PWR_OUT	Motor output phase V
CN1.6	W	PWR_OUT	Motor output phase W

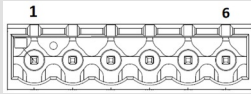

## CN4: Feedback input

12 positions, pitch 2.54mm double row, PCB header connector

CN4.1	SHIELD	/	Cable shield connection
CN4.2	HALL_C	DIG_IN	Hall effect signal C input
CN4.3	HALL_B	DIG_IN	Hall effect signal B input
CN4.4	HALL_A	DIG_IN	Hall effect signal A input
CN4.5	ENCZ+	DIG_IN	Encoder Zero input positive
CN4.6	ENCZ-	DIG_IN	Encoder Zero input negative
CN4.7	ENCB+	DIG_IN	Encoder phase B input positive
CN4.8	ENCB-	DIG_IN	Encoder phase B input negative
CN4.9	ENCA+	DIG_IN	Encoder phase A input positive
CN4.10	ENCA-	DIG_IN	Encoder phase A input negative
CN4.11	+5V	PWR_OUT	+5Vdc power supply output
CN4.12	GND	PWR_OUT	Negative side supply

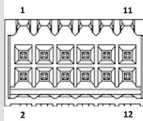

## CN3: Digital inputs/outputs

14 positions, pitch 2.54mm double row, PCB header connector

CN3.1	+B0_IN3	DIG_IN	Digital input B0_IN3 positive side
CN3.2	-B0_IN3	DIG_IN	Digital input B0_IN3 negative side
CN3.3	+B0_IN2	DIG_IN	Digital input B0_IN2 positive side
CN3.4	-B0_IN2	DIG_IN	Digital input B0_IN2 negative side
CN3.5	+B0_IN1	DIG_IN	Digital input B0_IN1 positive side
CN3.6	-B0_IN1	DIG_IN	Digital input B0_IN1 negative side
CN3.7	+B0_IN0	DIG_IN	Digital input B0_IN0 positive side
CN3.8	-B0_IN0	DIG_IN	Digital input B0_IN0 negative side
CN3.9	B0_OUT0	DIG_OUT	PNP digital output B0_OUT0
CN3.10	B0_OUT1	DIG_OUT	PNP digital output B0_OUT1
CN3.11	V-OUT	PWR_IN	24Vdc supply for digital output
CN3.12	VSS	PWR_IN	Negative input supply for digital outputs
CN3.13	B0_OUT2	DIG_OUT	PNP digital output B0_OUT2
CN3.14	VSS	PWR_IN	Negative input supply for digital outputs

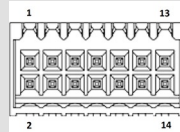

## CN6: Service SCI interface

4 positions, pitch 2mm double row, PCB header connector

CN6.1	TX/RX	Transmit / Receive Line	
CN6.2	DE/RE	Drive Enable Negated / Receive Enable	
CN6.3	+5V	+5V power out	
CN6.4	GND	DNG power out	

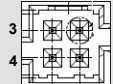

**This connection is only possible with hardware and software provided by Ever.**

## CN5A and CN5B: EtherCAT interface

RJ45, 8 positions shielded, PCB header connector

Dual RJ45 connectors (IN-OUT)

100BASE-TX (100Mb/sec) ports

Accept standard Ethernet cable (CAT5 or higher)

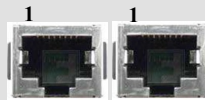

CN5B(IN) CN5A(OUT)

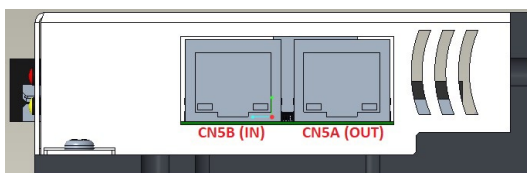

## Roto-Switches settings

EtherCAT ID Selection (Hexadecimal Value)										
R1 x 16 (MSD)	0	0	0	0	...	2	2	...	F	F
R2 x 1 (LSD)	0	1	2	3	...	C	D	...	E	F
ECAT-ID #	SW settings (default)	1	2	3	...	44	45	...	254	255

R1 (MSD): Most Significant Digit that must be multiplied per 16.

R2 (LSD): Least Significant Digit that must be multiplied per 1.

Example: 5C

R1 = 5 ----> 5x16 = 80

R2 = C ----> 12x1 = 12

EtherCAT ID = 92

**x 16  
(MSD)  
R1**

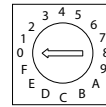

**x1  
(LSD)  
R2**

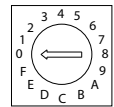

## Working Status (Led)

	Visualization status	Description
1		Green OFF Bus status 'Init'
2		Green ON Bus status 'Operational'
3		Green Blinking Bus status 'Pre-Operational'
4		Green Single Flash Bus status 'Safe-Operational'
5		Blue ON Error: connect with Service SCI kit and check with software
6		Blue ON Yellow ON Drive in boot mode. A new firmware should be downloaded to drive.
7		Blue ON Red Blinking (200ms) Initialization phase. Should last few seconds. While in this condition the drive is not fully operational
8		Yellow ON Missing setting of I <sub>nominal</sub>
9		Yellow Blinking (500 ms) Warning: connect with Service SCI kit and check with software
10		Red ON Protection: Motor is in open phase condition
11		Red Blinking (200ms) Current protection
12		Red ON (1 sec) + Yellow 1 Blink Under/Over voltage protection
13		Red ON (1 sec) + Yellow 3 Blink Thermal protection
14		Red ON (1 sec) + Yellow 4 Blink Motor feedback error
15		Red ON (1 sec) + Yellow 6 Blink Motor current regulation is out of range
16		Red ON (1 sec) + Yellow 7 Blink eePLC User Protection (generated by setting bit #0 of eePLC_User_Settings)



**Note :** Drive could be considered in a correct status if leds Red, Yellow and Blue are all OFF. In general:

- Led Blue indicates a software internal fault or a non-operative condition
- Led Red indicates an alarm or a drive protection
- Led Yellow indicates a warning

## Service SCI connection



This connection is only possible with hardware and software provided by Ever.  
Kit code: DW4\_SERV00-SL.

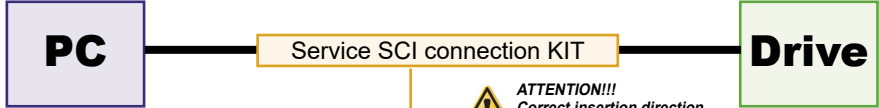

PC side

Drive side



**ATTENTION!!!**  
Correct insertion direction  
of the CN6: TAB UP.



## Encoder input connection

Electrically NOT-isolated digital inputs:  
- Differential 5Vdc that meet the RS422 standard  
- Single-Ended 5Vdc TTL/CMOS

**N.B. Maximum supply current of the 5V is 100 mA.**

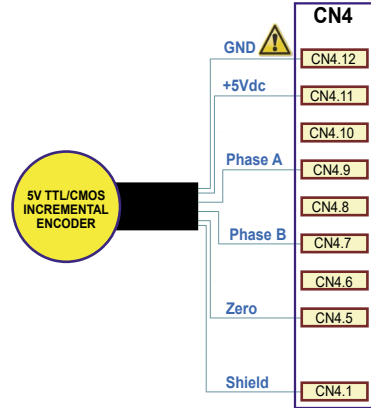
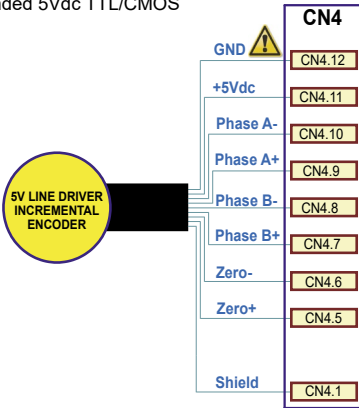

**GND is internally in common with power ground, this is potentially dangerous. Take all necessary measures to avoid possible contacts in the final installation.**

## Hall effects input connection

Electrically NOT-isolated digital inputs: Single-Ended 5Vdc TTL/CMOS

**N.B. Maximum supply current of the 5V is 100 mA.**

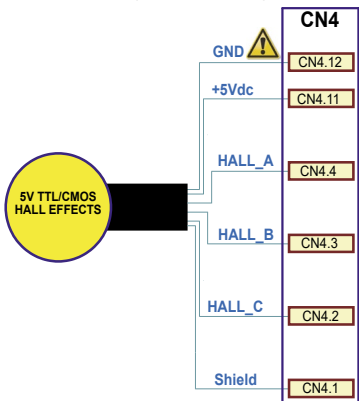

**GND is internally in common with power ground, this is potentially dangerous. Take all necessary measures to avoid possible contacts in the final installation.**



Differential PNP, NPN and Line Driver type.

## 3.3 - 24V INPUT

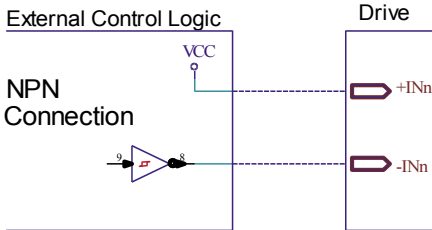
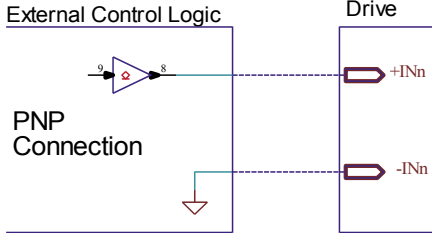

## 2 - 24V INPUT

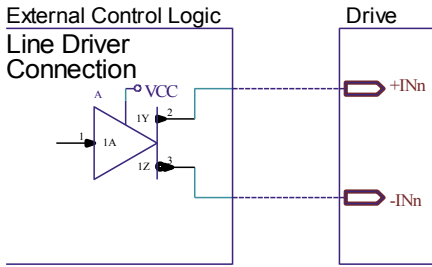

Standard Digital Inputs (B0_IN0 and B0_IN1)			
Characteristics	MIN.	MAX.	Unit
Supply voltage	2 <sup>(1)</sup>	24	Vdc
Inputs frequency	--	10	kHz
Threshold switching voltage	1.61 <sup>(1)</sup>	--	Vdc
Current at 2 Vdc <sup>(1)</sup>	--	2.53	mA
Current at 3.3 Vdc	--	5.84	mA
Current at 5 Vdc	--	6.28	mA
Current at 24 Vdc	--	8.75	mA

High-Speed Digital Inputs (B0_IN2 and B0_IN3)			
Characteristics	MIN.	MAX.	Unit
Supply voltage	2 <sup>(1)</sup>	24	Vdc
Inputs frequency	--	500	kHz
Threshold switching voltage	1.61 <sup>(1)</sup>	--	Vdc
Current at 2 Vdc <sup>(1)</sup>	--	2.53	mA
Current at 3.3 Vdc	--	5.84	mA
Current at 5 Vdc	--	6.28	mA
Current at 24 Vdc	--	8.75	mA

*(1) N.B.: it's recommended to use 2 Vdc digital inputs only in differential Line-Driver configuration to have more noise immunity.*

# Digital outputs connection

## B0\_OUT0 and B0\_OUT1

**i** PNP with  $V_{OUTmax} = 24\text{ Vdc}$ ,  $I_{OUTmax} = 100\text{ mA}$ ,  $F_{max} = 250\text{ kHz}$ .

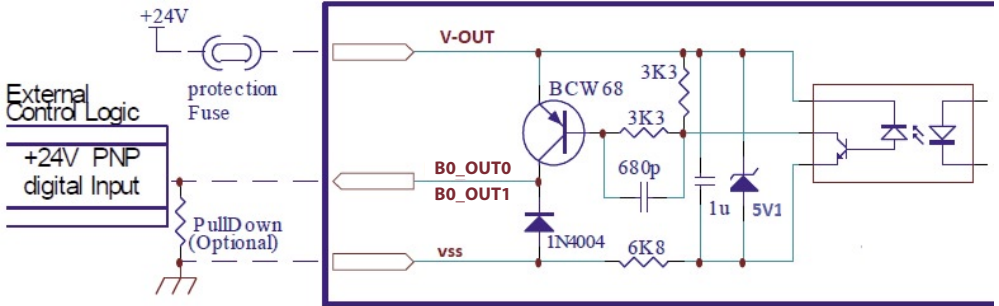

## B0\_OUT2

**i** PNP with  $V_{OUTmax} = 24\text{ Vdc}$ ,  $I_{OUTmax} = 1.3\text{ A}$ ,  $F_{max} = 250\text{ Hz}$ .

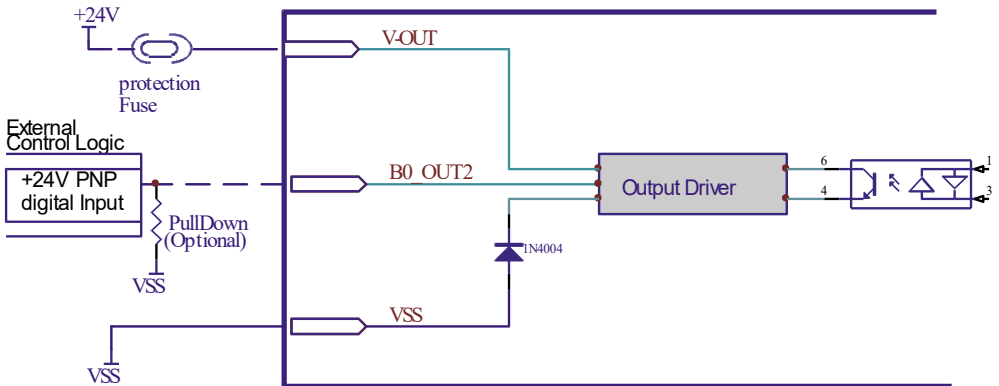

## Mating connectors

Connector	Description
CN1	Phoenix 1758830
CN3	Dinkle 0156-1B14-BK
CN4	Dinkle 0156-1B12-BK
CN5A / CN5B	RJ45, 8 positions Ethernet standard cables (CAT5 or higher)

## Section of the cables

Function	Cable	
	Minimum	Maximum
Power supply and PE	0.5 mm <sup>2</sup> (AWG20)	2.5 mm <sup>2</sup> (AWG12)
Motor outputs	0.5 mm <sup>2</sup> (AWG20)	2.5 mm <sup>2</sup> (AWG12)
Feedback / encoder input	0.14 mm <sup>2</sup> (AWG26)	0.5 mm <sup>2</sup> (AWG20)
Inputs and Outputs	0.14 mm <sup>2</sup> (AWG26)	0.5 mm <sup>2</sup> (AWG20)
EtherCAT interfaces	Ethernet standard cables (CAT5 or higher)	

## Verify the installation

- Check all connection: power supply and inputs/outputs.
- Make sure all settings right for the application.
- Make sure the power supply is suitable for the drive.
- If possible, remove the load from the motor shaft to avoid that wrong movements cause damage.
- Enable the current to the motor and verify the applied torque.
- Enable a movement of some steps and verify if the rotation direction is the desired one.
- Disconnect the power supply, connect the load on the motor and check the full functionality.

## Analysis of malfunctions



**When any of the following situations occur, the drive is placed in a fault condition.**

DEFECT	CAUSE	ACTION
Intervention of the thermal protection.	Can be caused by a heavy working cycle or a high current in the motor.	Improve the drive cooling by a natural or fan air flow. Consider to use a motor with a higher torque vs current rating.
Intervention of the current protection.	Short circuit on the motor powering stage(s) of the drive.	Check motor windings and cables to remove the short circuits replacing faulty cables or motor if necessary.
Intervention of the over/under voltage protection	Supply voltage out of range.	Check the value for the supply voltage.
Open phase motor protection.	Motor windings to drive not proper connection.	Check motor cables and connections to the drive.



**When any of the following situations occur, the drive doesn't work and isn't placed in an error condition.**

DEFECT	CAUSE	ACTION
Noisy motor movement with vibrations.	Can be caused by a lack of power supply to a phase of the motor or a poor regulation of the winding currents.	Check the cables and connections of the motor and/or change the motor speed to avoid a resonance region.
The external fuse on the power supply of the drive is burned.	Can be caused by a wrong connection of the power supply.	Connect the power supply correctly and replace the fuse.
At high speed, the motor torque is not enough.	Can be due to a 'self-limitation' of motor current and torque.	Increase the motor current (always within the limits), increase the supply voltage, change motor connection from series to parallel.

**EVER Elettronica**

Via del Commercio, 2/4 - 9/11

Loc. San Grato Z. I

26900 - L O D I - Italy

Phone +39 0371 412318 - Fax +39 0371 412367

email: infoever@everelettronica.it

web: www.everelettronica.it

