

Installation instructions

i Refer to installation use and maintenance manual for more information.
Available user manual at link <http://www.everelettronica.it/manhw.html>



Bipolar drive integrated with 2 phase step motor

- AC power Supply: $18 \pm 56\text{Vac}$;
- DC Logic Supply: 24Vdc (optional);
- Phase current : up to 4,2 ARMS (6 APK);
- Chopper frequency: ultrasonic 40KHz;
- Stepless Control Technology (65536 position per turn);
- Protections: over-current, over-temperature, short circuit phase-phase motor and phase-ground;
- Modbus or Canbus communication interfaces;
- Service SCI interface for programming and real time debugging;
- Digital inputs (opto-coupled);
- Digital outputs (opto-coupled);
- Analog input (opto-coupled);
- Size and mass: Length (mm)x124x60mm. Connectors not included(L x D x H : refer to picture);
- IP protection: IP65;
- Working temperature $5^{\circ}\text{C} \pm 40^{\circ}\text{C}$; Storage temperature $-25^{\circ}\text{C} \pm 55^{\circ}\text{C}$;
- Humidity : $5\% \pm 85\%$ not condensing;

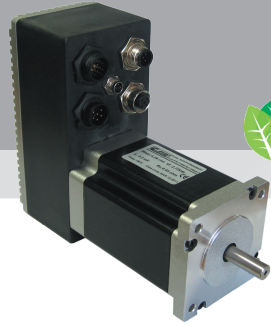

Mechanical data

i Handle systems with care by taking them from the motor side and not from the electronics side.

Shaft axial load = 15 N max
Shaft radial load = 75 N max (on front shaft end)

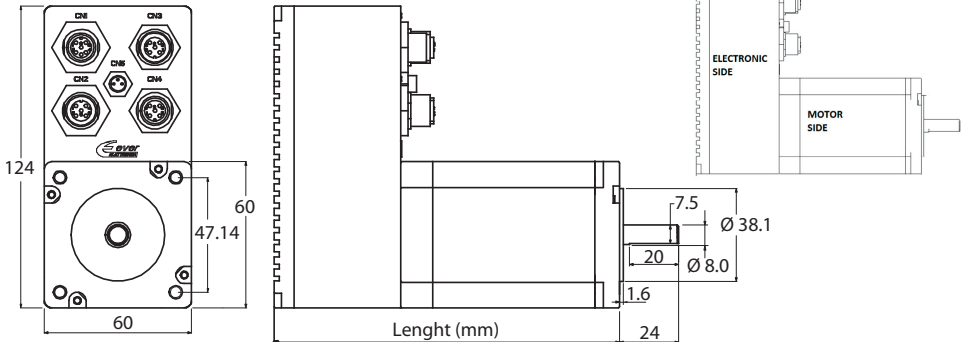

Composition code	SM4A	3	42P	x	2	y	2	z	w	0
------------------	-------------	----------	------------	----------	----------	----------	----------	----------	----------	----------

Model (z letter)	Length (mm)	Shaft Ø (mm)	D-cut on shaft (mm)	Holding Torque (Nm)	Rotor Inertia (g.cm ²)
SM4A342P_2_2_2_0	100.5	8.0	7.5 x 20	1.1	275
SM4A342P_2_2_2_0	110.5	8.0	7.5 x 20	1.65	300
SM4A342P_2_2_2_0	120.5	8.0	7.5 x 20	2.1	570
SM4A342P_2_2_2_0	140.5	8.0	7.5 x 20	3.3	840

Model (w letter)	Incremental Encoder (ppr)
SM4A342P_2_2_2_0	Without encoder
SM4A342P_2_2_2_40	400
SM4A342P_2_2_2_50	1000
SM4A342P_2_2_2_60	2000

System connections

Connectors:

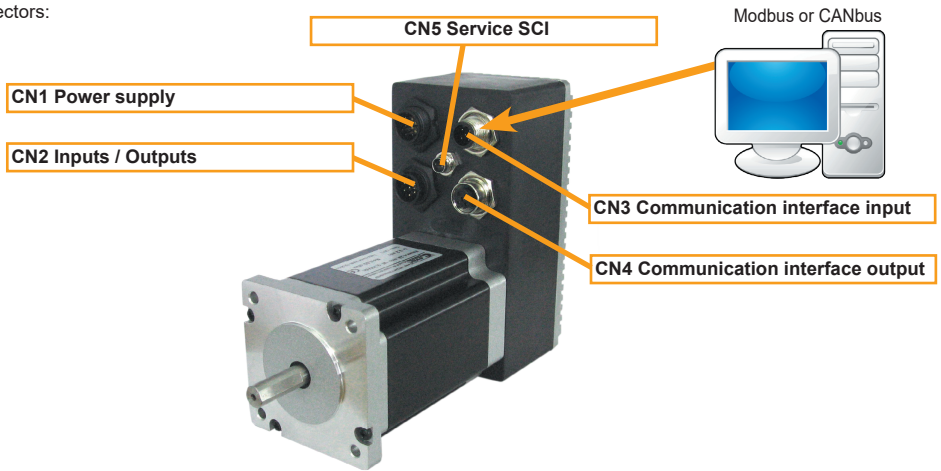

Power and Logic supplies are not isolated but they have common reference inside the drive.



Use two separate and isolated supply for logic and digital outputs.



Connect GND of the logic supply and VSS of the output supply to PE near to the origin of the supplies with two different wires.



Do not connect simultaneously PE to the secondary circuit of the power transformer and to GND of the logic supply, otherwise the drive breaks and becomes unusable.

Composition code	SM4A	3	42P	x	2	y	2	z	w	0
------------------	------	---	-----	---	---	---	---	---	---	---

CN1 Power supply

CN1.1	AC in	PWR_IN	AC power supply 18 ÷ 56 Vac
CN1.2	AC in	PWR_IN	AC power supply 18 ÷ 56 Vac
CN1.3	PE	EARTH	Protective Earth
CN1.4	n.c.	---	Not connected
CN1.5	+Vlog	PWR_IN	Positive logic supply input +24 Vdc (optional)
CN1.6	-Vlog	PWR_IN	Negative logic supply input GND (optional)

Connector
Type: screw, 6 pins, male, IP67
Manufacturer: LTW
Model: LTWBWD-06PMMS-SC7001

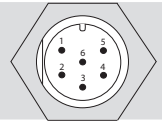

CN2 Inputs and outputs

y = 4 : 4 digital inputs and 2 digital outputs

CN2.1	+B0_IN0	DIG_IN	Digital input positive side
CN2.2	-B0_IN0	DIG_IN	Digital input negative side
CN2.3	+B0_IN1	DIG_IN	Digital input positive side
CN2.4	-B0_IN1	DIG_IN	Digital input negative side
CN2.5	+B0_IN2	DIG_IN	Digital input positive side
CN2.6	-B0_IN2	DIG_IN	Digital input negative side
CN2.7	+B0_IN3	DIG_IN	Digital input positive side
CN2.8	-B0_IN3	DIG_IN	Digital input negative side
CN2.9	B0_OUT0	DIG_OUT	PNP digital output OUT0
CN2.10	B0_OUT1	DIG_OUT	PNP digital output OUT1
CN2.11	+24 V	PWR_IN	Input positive power supply digital outputs
CN2.12	VSS	PWR_IN	Negative reference power supply digital outputs

Connector
Type: 12 pins panel rear mount screw type, male, IP67
Manufacturer: LTW
Model: LTWBU-12PMMS-SC7001

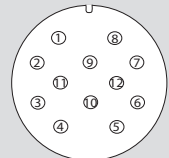

y = 7 : 4 digital inputs, 2 digital outputs and 1 analog input

CN2.1	+B0_IN0	DIG_IN	Digital input positive side
CN2.2	+IN_AN0	AN_IN	Analog input positive side
CN2.3	+B0_IN1	DIG_IN	Digital input positive side
CN2.4	-IN_AN0	AN_IN	Analog input negative side
CN2.5	+B0_IN2	DIG_IN	Digital input positive side
CN2.6	V_POT	PWR_OUT	Voltage supply for potentiometer
CN2.7	+B0_IN3	DIG_IN	Digital input positive side
CN2.8	COM_IN	PWR_IN	Reference digital inputs and outputs
CN2.9	AGND	PWR_OUT	Output negative reference for potentiometer
CN2.10	B0_OUT0	DIG_OUT	PNP digital output OUT0
CN2.11	B0_OUT1	DIG_OUT	PNP digital output OUT1
CN2.12	+24V	PWR_IN	Input positive power supply digital outputs

System connections

Composition code	SM4A	3	42P	x	2	y	2	z	w	0
------------------	-------------	----------	------------	----------	----------	----------	----------	----------	----------	----------

CN3 Communication interface input

x = C : CANbus			
CN3.1	n.c.	---	Not connected
CN3.2	n.c.	---	Not connected
CN3.3	CAN_GND	PWR output	Signal ground
CN3.4	CAN_H	Digital I/O	Bus Line High
CN3.5	CAN_L	Digital I/O	Bus Line Low
x = M : Modbus RS485			
CN3.1	n.c.	---	Not connected
CN3.2	n.c.	---	Not connected
CN3.3	0V_A	PWR output	Signal ground
CN3.4	Data +	Digital I/O	Not inverting signal RS485
CN3.5	Data -	Digital I/O	Inverting signal RS485

Connector
Type: M12, 5 pins, male, IP68
Manufacturer: LTW
Model: LTW1205-05PMMS-SF8001

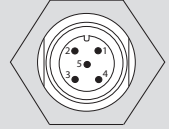

CN4 Communication interface output

x = C : CANbus			
CN4.1	n.c.	---	Not connected
CN4.2	n.c.	---	Not connected
CN4.3	CAN_GND	PWR output	Signal ground
CN4.4	CAN_H	Digital I/O	Bus Line High
CN4.5	CAN_L	Digital I/O	Bus Line Low
x = M : Modbus RS485			
CN4.1	n.c.	---	Not connected
CN4.2	n.c.	---	Not connected
CN4.3	0V_A	PWR output	Signal ground
CN4.4	Data +	Digital I/O	Not inverting signal RS485
CN4.5	Data -	Digital I/O	Inverting signal RS485

Connector
Type: M12, 5 pins, female, IP68
Manufacturer: LTW
Model: LTW1205-05PFFS-SF8001

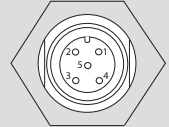

CN5 Service SCI interface

x = C : CANbus			
CN5.1	GND	PWR_OUT	GND power output
CN5.2	+5E	PWR_OUT	+5V power output
CN5.3	DE / RE	DIG_OUT	Drive enable negated / Receive enable
CN5.4	TX / RX	Digital I/O	Transmit / Receive line

Connector
Type: M12, 5 pins, female, IP68
Manufacturer: LTW
Model: LTW1205-05PFFS-SF8001

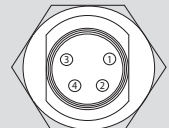

This connection is possible *only* with hardware and software provided by EVER Co.
 Kit code: **SM4A_SERVO-KIT**



Digital inputs connection

Composition code	SM4A	3	42P	x	2	y	2	z	w	0
------------------	------	---	-----	---	---	---	---	---	---	---



Differential PNP, NPN and Line Driver type or single-ended PNP type.

VERSION -----> y = 4

3.3 - 24V Differential

2 - 24V Differential

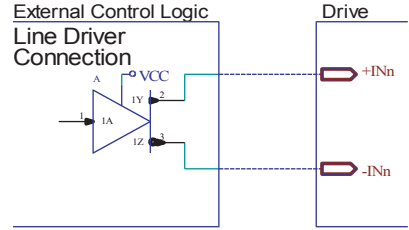
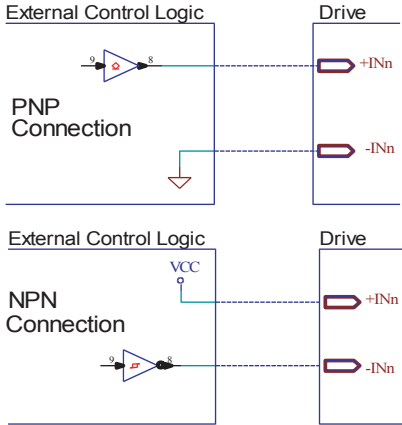

VERSION -----> y = 7

3.3 - 24V Single Ended

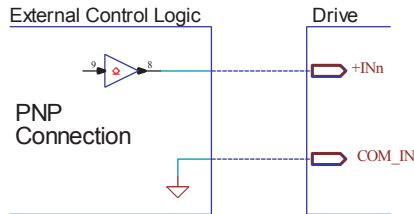

With single-ended configuration, digital inputs have common ground (COM_IN) with digital outputs.

Take this in consideration in the final installation.

N.B. It's recommended to use 2Vdc digital inputs only in Differential Line-Driver configuration to have more noise immunity.

Digital outputs connection

Digital outputs $V_{outmax} = 24Vdc$, $I_{outmax} = 100mA$

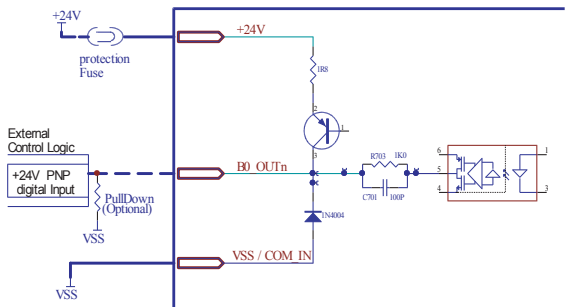

Analog input connection



The resolution of the analog input depends from the type of the connection which could be defined by software: differential or potentiometer.

Differential connection

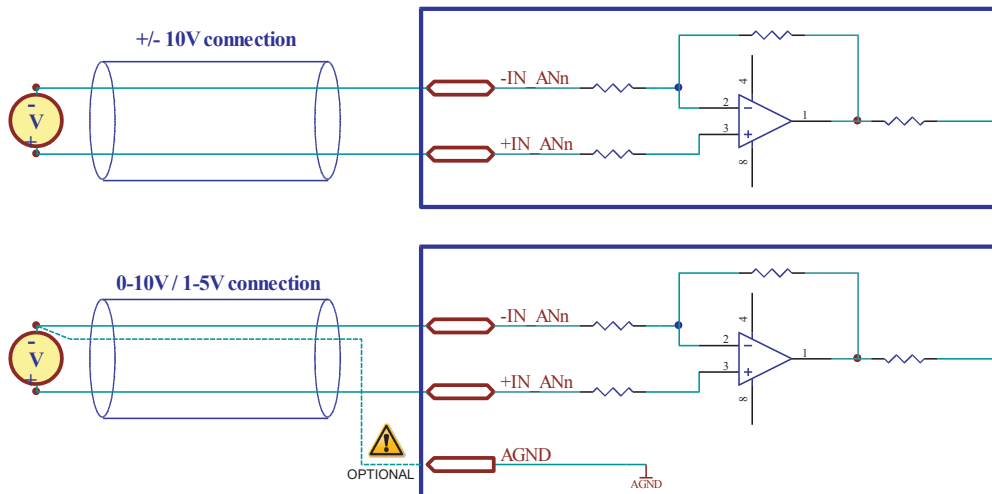

The connection from an external reference and $AGND$ should be preceded by a thorough risk analysis on the machine/circuit in which the drive will be installed.

Potentiometer connection

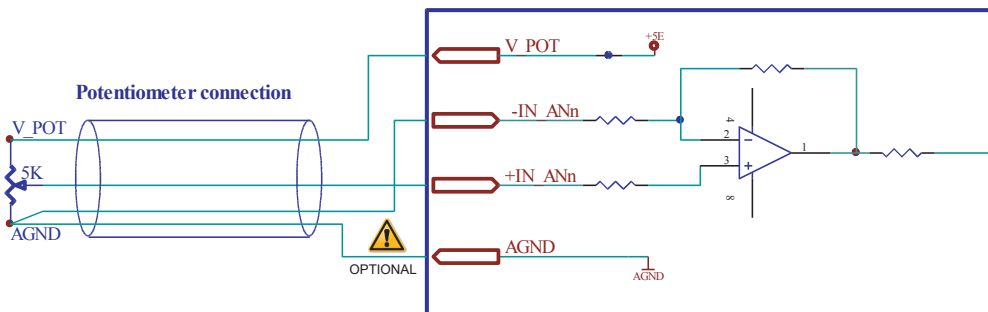

$AGND$ is internally in common with power ground, this is potentially dangerous. Take all necessary measures to avoid possible contacts in the final installation.

Mating cable kit

Connection	Connector kit information		Kit order code
CN1	Pin: Pinout: Conductors: Cable: Waterproof rate:	6 position 1 - Blue, 2 - Green, 3 - Yellow, 4 - Orange, 5 - Red, 6 - White. UL2464 - Black PVC Jacket (UV resistant) ext. Ø 6.5mm IP67	CA/LTWBD06BFnn nn = 01 (1 mt.) 05 (5 mt.) 10 (10 mt.)
CN2	Pin: Pinout: Conductors: Cable: Waterproof rate:	12 position 1 - Brown, 2 - Blue, 3 - White, 4 - Green, 5 - Yellow, 6 - Grey, 7 - Pink, 8 - Red, 9 - Black, 10 - Orange, 11 - Purple, 12 - Green/White. UL2464 - Black PVC Jacket (UV resistant) ext. Ø 6.5mm IP67	CA/LTWBU12BFnn nn = 01 (1 mt.) 05 (5 mt.) 10 (10 mt.)
CN3	Pin: Pinout: Conductors: Cable: Waterproof rate:	5 position 1 - Brown, 2 - White, 3 - Blue, 4 - Black, 5 - Green or Gray. UL2464 - Black PVC Jacket (UV resistant) ext. Ø 6.0mm IP68	CA/LTW1205BFnn nn = 01 (1 mt.) 05 (5 mt.) 10 (10 mt.)
CN4	Pin: Pinout: Conductors: Cable: Waterproof rate:	5 position 1 - Brown, 2 - White, 3 - Blue, 4 - Black, 5 - Green or Gray. UL2464 - Black PVC Jacket (UV resistant) ext. Ø 6.0mm IP68	CA/LTW1205BMnn nn = 01 (1 mt.) 05 (5 mt.) 10 (10 mt.)
CN5	Pin: Pinout: Conductors: Cable: Waterproof rate:	4 position 1 - Brown, 2 - White, 3 - Blue, 4 - Black. UL2464 - Black PVC Jacket (UV resistant) ext. Ø 6.0mm IP68	CA/LTW0804BFnn nn = 01 (1 mt.) 05 (5 mt.) 10 (10 mt.)

Section of the cables

Function	Cable	
	Minimum	Maximum
Power supply	0.5 mm ² (AWG20)	2.5 mm ² (AWG12)
Communication interface	0.25 mm ² (AWG23) CANbus CIA-CANopen	
Digital inputs	0.14 mm ² (AWG25)	0.5 mm ² (AWG20)
Digital outputs	0.14 mm ² (AWG25)	0.5 mm ² (AWG20)

Verify the installation

- Check all connection: power supply and inputs/outputs.
- Make sure all settings right for the application.
- Make sure the power supply is suitable for the drive.
- If possible, remove the load from the motor shaft to avoid that wrong movements cause damage.
- Enable the current to the motor and verify the applied torque.
- Enable a movement of some steps and verify if the rotation direction is the desired one.
- Disconnect the power supply, connect the load on the motor and check the full functionality.

Analysis of malfunctions



When one of the following situations occur, the drive doesn't function correctly and it is reported an error.

DEFECT	CAUSE	ACTION
The external fuse to the drive burns.	May be due to a wrong connection of the power supply.	Adjust the connection and recover the fuse. Use a fuse suitable for the application.
Over temperature protection.	May be due to a duty cycle.	Increase the air flux and if it is possible chose a motor with higher torque at same current value.
Over current protection.	May be due to a short circuit on the motor power stage.	Shut down the power supply and check if the motor is damaged.
Noisy motor movement with vibrations.	May be caused due to a state of resonance.	Increase the resolution of the step angle and/or change the motor velocity to avoid resonance area.
The motor produce torque but doesn't rotate.	May be caused due to a wrong connection of the I/O's.	Check the connection of the I/O's.

EVER Elettronica
Via del Commercio, 2/4 - 9/11
Loc. San Grato Z. I
26900 - L O D I - Italy
Phone +39 0371 412318 - Fax +39 0371 412367
email: infoever@everelettronica.it
web: www.everelettronica.it

